

SELF-PRIMING FRAME MOUNTED PUMP

Series: BSP20MU

3" x 3"

Universal Drive

Spherical solids handling: 3/4"



SUCTION

3" NPT, female flange.

DISCHARGE

3" NPT, female.

LIQUID TEMPERATURE

Continuous: 160 °F (71 °C)

VOLUTE

Cast iron ASTM A-48 class 30

BODY

Cast iron ASTM A-48 class 30

PEDESTAL

Cast iron ASTM A-48 class 30

IMPELLER

Design: 5 vanes, semi-open type, dynamically balanced.

Material: Cast iron ASTM A-48 class 30

SHAFT

Steel

SHAFT SLEEVE

Steel

HARDWARE

Steel

O-RINGS

Buna-N

PAINT

Air dry enamel, water based.

SEAL

Design: single mechanical with lip seal, water lubricated.

Material: ceramic stationary part, carbon ring seal and exclusion in the rotating part. Buna-N elastomer and stainless steel spring.

CHECKVALVE

Valve: flap-neoprene

Weight: steel

BEARING-DRIVE END

Single row, cone, oil lubricated.

BEARING-PUMP END

Single row, cone, oil lubricated.

SHIM SET

Stainless steel

STRAINER

Steel

SPECIFICATIONS

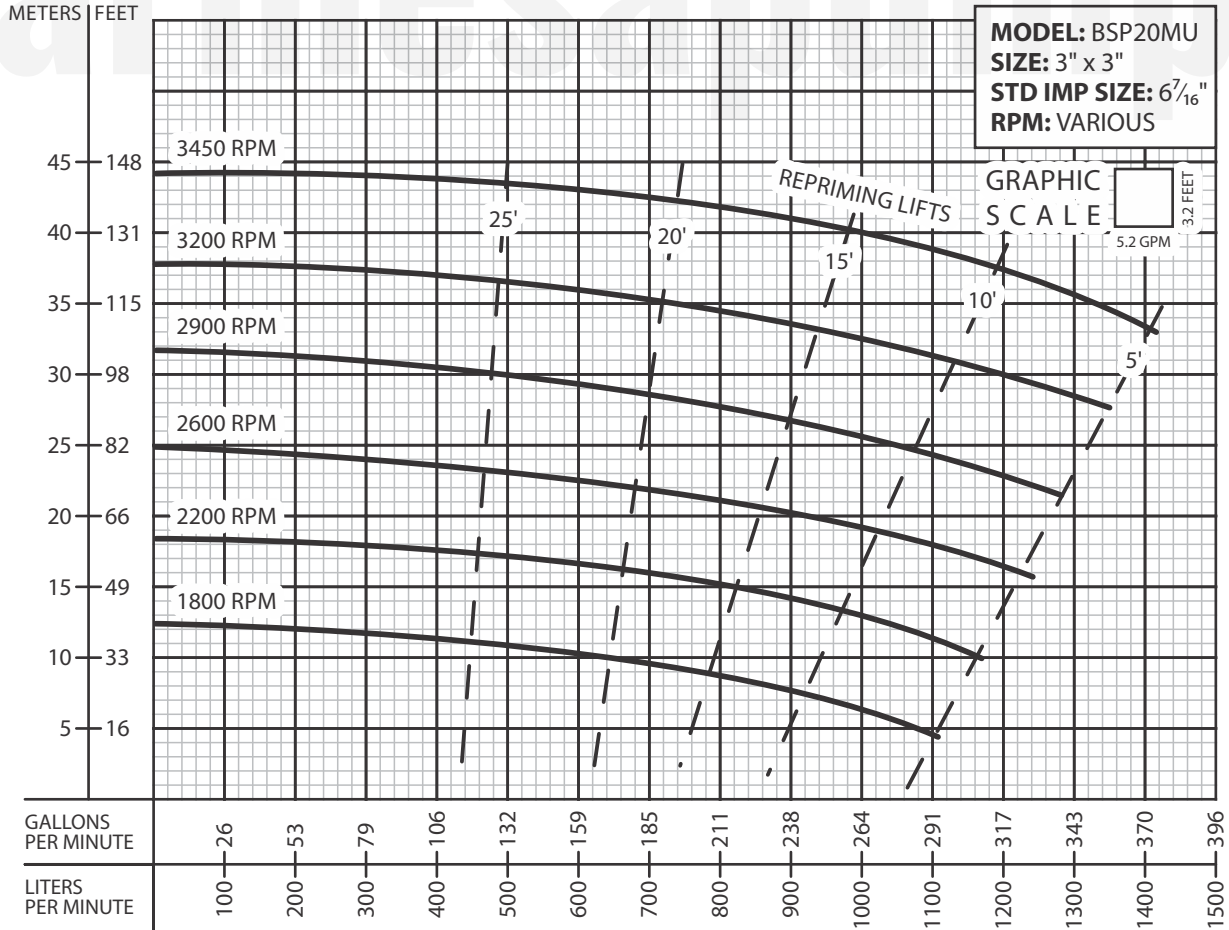
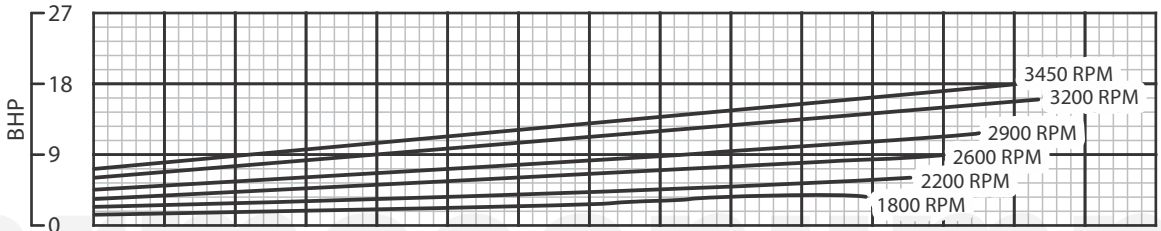
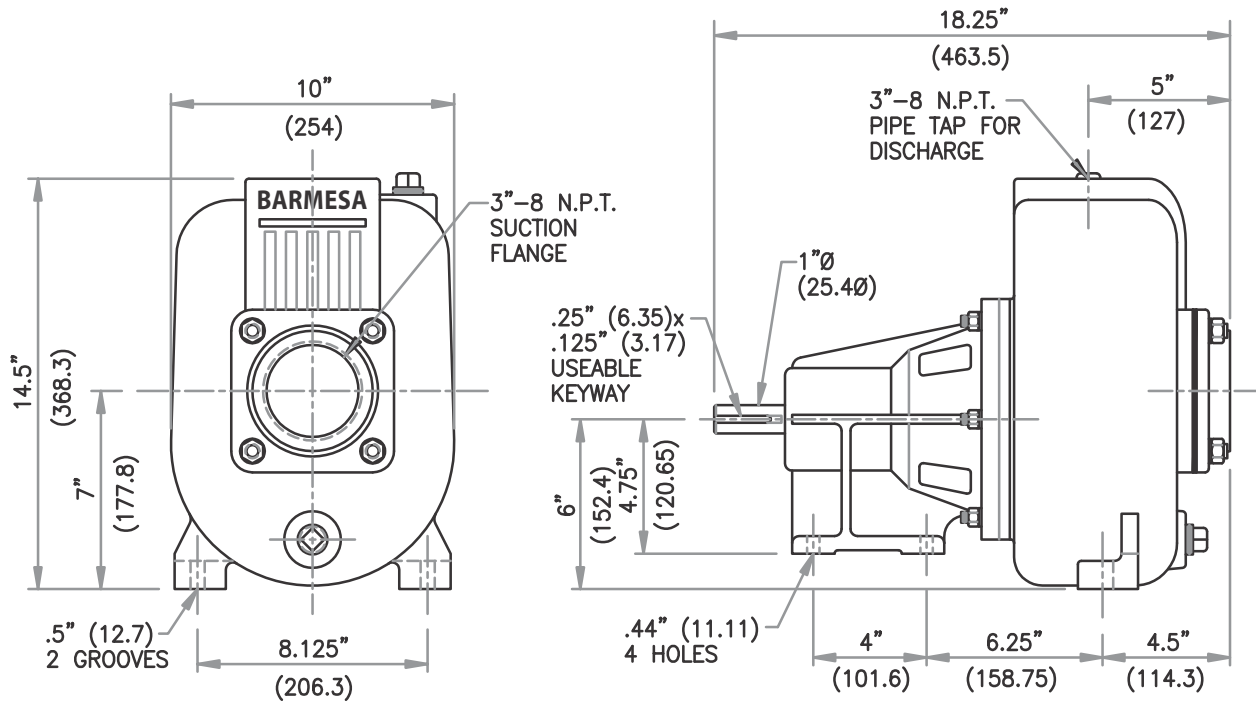

IMPORTANT!

1. Testing is performed with water specific gravity of 1.0 @ 68°F (20°C); other fluids may vary performance.