

SUBMERSIBLE SOLIDS HANDLING X-PROOF PUMP

Series: 6XBSE75044HADS

75 HP / 1750 RPM

Discharge: 6"

Spherical solids handling: 3"



Representative image.

DISCHARGE

6", 125 lb, flange horizontal.

LIQUID TEMPERATURE

104°F (40°C) continuous.

VOLUTE

Cast iron ASTM A-48 class 30.

WEARING RING

Bronze.

MOTOR HOUSING

Cast iron ASTM A-48 class 30.

SEAL PLATE

Cast iron ASTM A-48 class 30.

IMPELLER

Design: 3 vane, closed, with vanes on back side.

Material: cast iron ASTM A-48 class 30.

SHAFT

416 series stainless steel.

PAINT

Air dry enamel, water based.

HARDWARE

300 series stainless steel.

SEAL

Design: double, mechanical, oil filled chamber.

Material: silicon carbide outboard seal, carbon ceramic inboard seal, Buna-N elastomer and stainless steel hardware.

CORD ENTRY

25 ft of neoprene cord 2/4 G, sealed against moisture.

BEARINGS

Upper: ball, single row, oil lubricated, for radial load.

Lower: ball, double row, grease lubricated, for radial and thrust load.

MOTOR

NEMA B, three phase, 460 volts, 60 Hz, 1750 RPM, air cooled. Explosion Proof, Class 1, Division 1, Group C & D, insulation Class F. Requires overload protection to be included in control panel.

MOISTURE SENSOR

Normally open (N/O) included.

TEMPERATURE SENSOR

Normally closed (N/C) included.

OPTIONAL EQUIPMENT

Impeller trimming, additional cord, tungsten carbide seal, slide rail coupling (SRC-6).

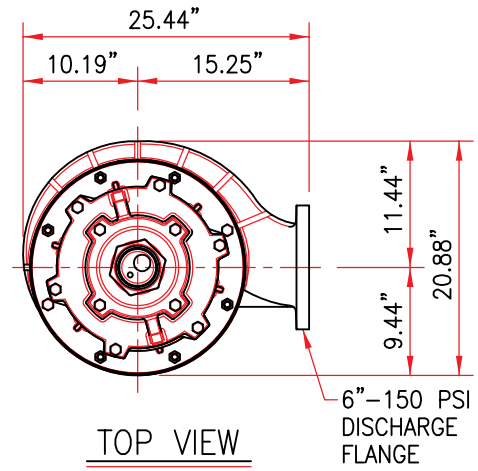
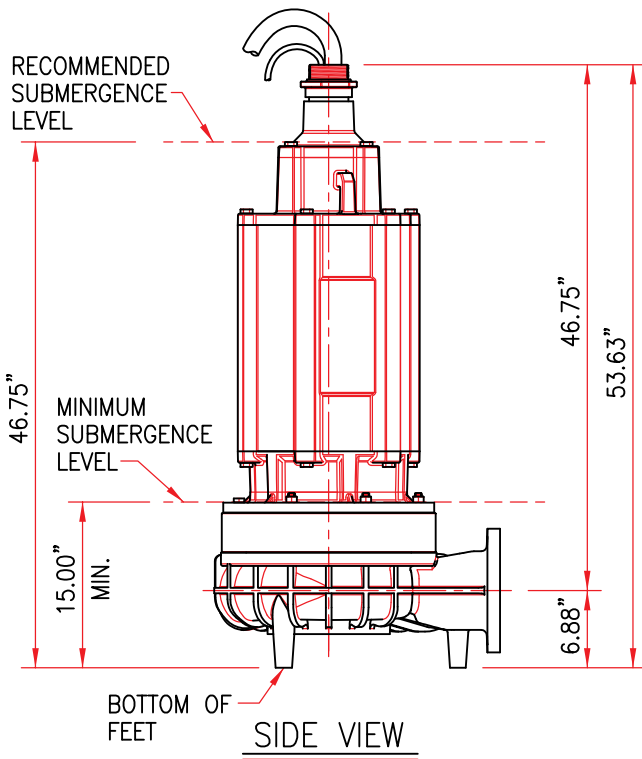

ALL DIMENSIONS IN INCHES.

ELECTRIC MOTOR SPECS:

BRAND: BALDOR-RELIANCE
 HP: 75
 RPM: 1770
 VOLTS: 460
 HZ: 60
 PH: 3
 FRAME: 320TY
 ENCL: TENV

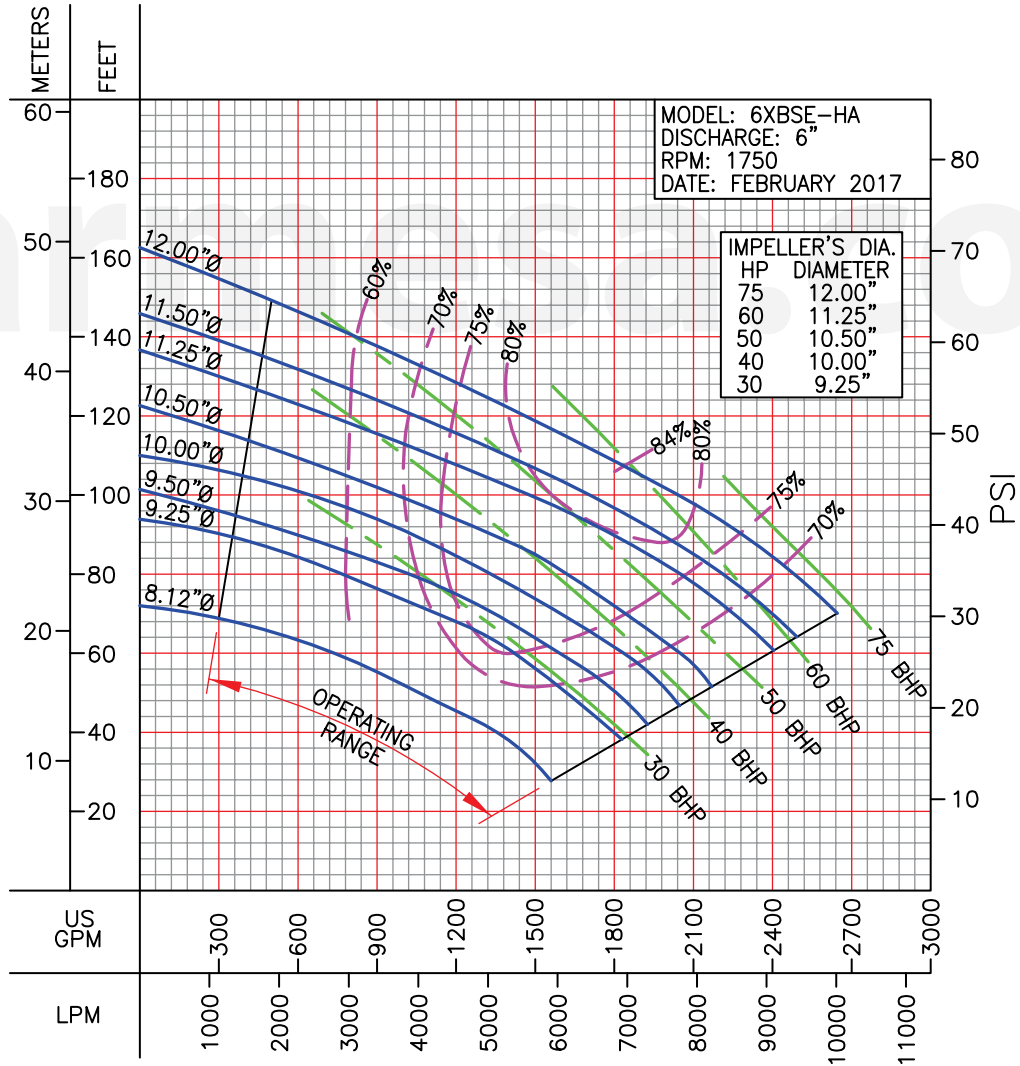

IMPORTANT!

1. Never use this pump to handle explosive liquids.
2. This pump is not approved to be used in swimming pools, recreational installations or any application where human contact may be common.
3. Pump may be operated "dry" for extended periods without damage to motor and/or seals.
4. Testing is performed with water specific gravity of 1.0 @ 68 °F (20 °C); other fluids may vary performance.